

■Features

- High luminous flux
- Super energy efficiency
- Very long operating life
- Superior UV resistance

■Applications

- Read lights (car, bus, aircraft)
- Portable (flashlight, bicycle)
- Bollards / Security / Garden
- Traffic signaling / Beacons
- Indoor / Outdoor commercial lights
- Automotive Ext

■Outline Dimension

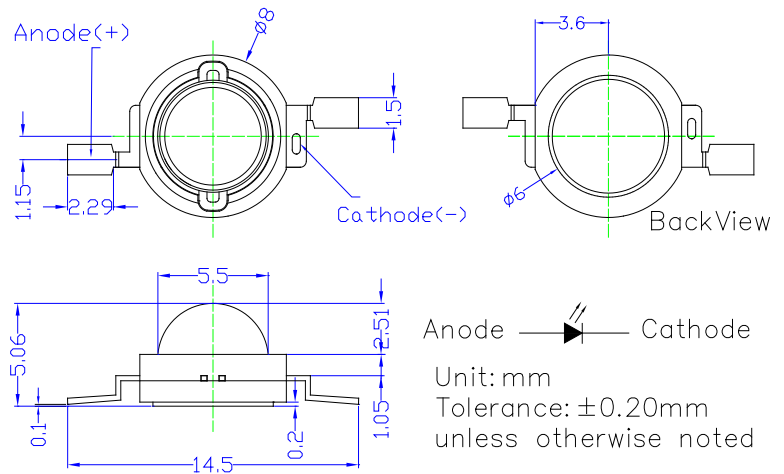

■Absolute Maximum Rating

(Ta=25°C)

Item	Symbol	Value	Unit
DC Forward Current	I _F	100	mA
Pulse Forward Current#	I _{FP}	150	mA
Reverse Voltage	V _R	15	V
Power Dissipation	P _D	1350	mW
Operating Temperature	T _{opr}	-30 ~ +85	°C
Storage Temperature	T _{stg}	-40~ +100	°C
Manual Soldering Temperature	T _{sol}	350°C/3sec	-

#Pulse width Max.10ms Duty ratio max 1/10

■Directivity

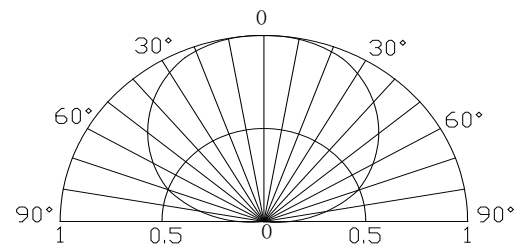

■Electrical -Optical Characteristics

(Ta=25°C)

Item	Symbol	Condition	Min.	Typ.	Max.	Unit
DC Forward Voltage*1	V _F	I _F =80mA	-	12.5	13.5	V
DC Reverse Current	I _R	V _R =15V	-	-	10	μA
Luminous Flux *2	Φ _v	I _F =80mA	110	130	-	lm
Color Temperature*3	CCCT	I _F =80mA	2700	3000	3300	K
Chromaticity Coordinates*4	x	I _F =80mA	-	0.44	-	-
	y	I _F =80mA	-	0.41	-	-
50% Power Angle	2θ _{1/2}	I _F =80mA	-	140	-	deg

*1 Tolerance of measurements of forward voltage is ±0.1V

*2 Tolerance of measurements of luminous flux is ±15%

*3 Tolerance of measurements of color temperature is ±10%

*4 Tolerance of measurements of chromaticity coordinate is ±10%

Note: Don't drive at rated current more than 5s without heat sink for Xeon 1 emitter series.

■ **Soldering Heat Reliability:**

Reflow soldering Profile

- Reflow soldering should not be done more than two times.
- When soldering, do not put stress on the LEDs during heating.
- After soldering, do not warp the circuit board.
- Repairing should not be done after the LEDs have been soldered. When repairing is unavoidable, a double-head soldering iron should be used. It should be confirmed beforehand whether the characteristics of the LEDs will or will not be damaged by repairing.

Solder
Average ramp-up rate = 3°C/sec. max.
Preheat temperature: 150°~180°C
Preheat time = 120 sec. max.
Ramp-down rate = 6°C/sec. max.
Peak temperature = 220°C max.
Time within 3°C of actual peak temperature = 25 sec. max.
Duration above 200°C is 40 sec. max.

